

ALEXANDRA

X-1071 ALEXANDRA

REND. 66%

N.O. 16,5 kW

CO to 13% O₂ = 0,7%

C.H. 6 kg

UNE-EN 13240

Weight 180 kg

VOL. 1,26 m³

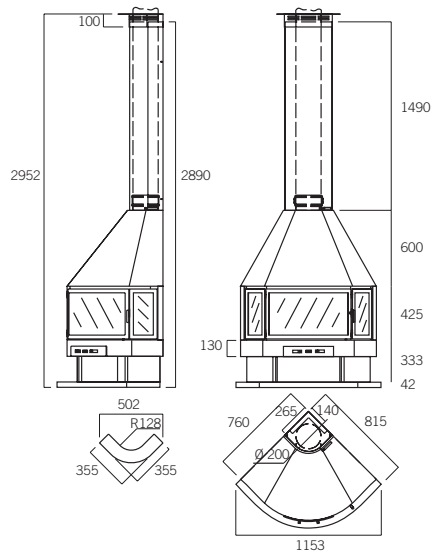

OPTIONAL ELEMENTS



X-1070-2/1
Flue cover



X-1070-1/3
Special finishing piece



X-1070-1/2
Inclined finishing piece